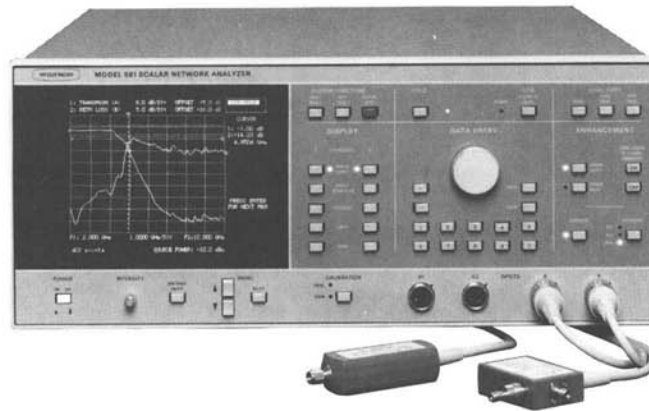

Scalar Network Analyzer

Model 561, 10 MHz to 40 GHz

561 Scalar Network Analyzer Highlights

- Automatic Measurements and Hard Copy Output Without a Controller
- Accurate Coaxial Measurements from 10 MHz to 40 GHz
- Nine Stored Setups to Eliminate Set-Up Time
- Cursors, Markers, and Limit Lines to Improve Productivity
- Complete, Annotated, Step-By-Step Normalization and Measurement Procedures
- Four Measurement Channels
- Lowest Cost Network Analyzer

Automated Measurement System

With the addition of a sweep generator, the 561 becomes an automated transmission, return loss (SWR), and power measurement system. Operating over the 10 MHz to 40 GHz range from a single coaxial test port, the system provides fully annotated displays of test data and measurement parameters.

Under internal microprocessor control (no external controller required), the 561 normalizes and simultaneously displays any two inputs on channels A, B, R1, and R2. The same inputs can be displayed as ratios A/R1, A/R2, B/R1, or B/R2. The dynamic range for each channel is 71 dB (-55 dBm to +16 dBm). Typically, the noise floor is less than -62 dBm, providing a greater than 76 dB dynamic range in almost all applications.

Normalization and Measurement

In a typical 561 test setup, the test device is inserted between the SWR Autotester and the detector. Detected signals from the SWR Autotester vary in proportion to the reflections, while the detector output varies in proportion to transmission loss or gain. The detector can be used to measure power in dBm.

During normalization, procedural guidance is automatically provided for transmission and return loss measurements. For return loss tests, a 0 dB reference is established by connecting an open and then a short to the SWR Autotester test port. The normalization data are taken independent of sensitivity settings at 2001 points with 0.002 dB resolution and stored in memory for correction of test data or for recall. Furthermore, an algorithm interpolates between data points to hold interpolated test data accuracy to within ± 0.1 dB. Therefore, once the 561 has been normalized across a user-selected frequency range, measure-

ments can be made over any portion of the range without renormalization. Set-up time is virtually eliminated by storing parameters for up to nine test setups.

During measurements, data are taken at 101, 201, or 401 points (user selected) with 0.005 dB vertical resolution on both channels. Typically, test data are updated every 100 ms, allowing "real time" adjustment of the test device. A permanent record of the test data—with or without the test, marker, or stored setup parameters—is made automatically on an HP 7440A, 7470A, or 7475A plotter or on most dot-matrix printers, including the Epson FX and the optional 2225C Ink Jet Printer. Since the 561 requires only about 10 seconds for print formatting, a new test can be conducted while the previously taken data are being printed out.

The 561 is equally effective in waveguide reflectometer setups where ratio measurements may be preferred. The 560-10BX, -1 Adapter Cables provide the interface between the instrument and waveguide detectors.

Cursors, Markers, and Limit Lines

The 561 has the most extensive set of cursor functions available on a scalar network analyzer:

Main Cursor: Position of the cursor is continuously variable with the tuning knob. The frequency and amplitude of the test data at the cursor on both traces are digitally displayed.

Cursor Delta: The difference in amplitude and frequency between the reference cursor and the Main Cursor positions on the test data are displayed for both traces. To establish a new reference, the position of the two cursors can be reversed by making a menu selection.

Cursor Min/Max: The 561 automatically moves the cursor to the minimum or maximum value of test data on either trace and displays the value in dB or dBm.

Cursor "X" dB: The cursor automatically moves to the amplitude on either trace where the test data is equal to the entered value of "X" dB or dBm.

Cursor "X" Bandwidth: Cursors are automatically displayed above and below the cursor at the frequencies where the test data are equal to the entered value "X" dB. The frequencies of the low and high cursors and the bandwidth between them are displayed.

Cursor Next Marker: The cursor automatically moves to the next highest frequency marker.

Cursor Active Marker: The cursor automatically moves to the frequency of the active marker.

These cursor functions are in addition to the eight markers available when the Wiltron 6600B Sweep Generator is used as the system signal source. Through a dedicated GPIB link, the 561 communicates with the signal source and displays an identifier for each marker, as well as the frequency and amplitude of the active marker.

To speed the interpretation of data, complex limit lines can be entered through the front panel or the GPIB interface. Limit lines can have up to nine segments which slope or step with frequency.

Averaging and Smoothing

When characteristics of the test device vary rapidly with frequency at very low signal levels, the trace can be smoothed by averaging and/or smoothing. The Smoothing control has three selections: Off, Min, and Max. To maintain the accuracy of the measurement data, smoothing is performed by reducing bandwidth, rather than by averaging adjacent data points in order to preserve measurement detail.

When averaging is selected, 2 to 256 successive traces can be averaged to smooth the trace display. As various combinations of smoothing and averaging are selected, the trace update time is automatically adjusted.

Measurement Accuracy

The return-loss accuracy of the 561 is largely attributable to the high directivity of the Wiltron SWR Autotesters. For example, the 560-97A50-1 with its GPC-7 test port connector has a directivity of better than 40 dB from 10 MHz to 18 GHz. On the 560-98K50, the directivity exceeds 35 dB up to 18 GHz, 32 dB up to 26.5 GHz, and 30 dB up to 40 GHz. The same unit has a test port match of better than 23 dB up to 26.5 GHz and 15 dB up to 40 GHz. To avoid the use of error-producing adapters, SWR Autotesters are available with either male or female test ports in Type N, WSMA, or K Connectors, all with high directivity. When the GPC-7 test port is selected, the lowest reflection adapters obtainable are offered in Type N and WSMA, which is optimized for testing SMA devices.

The accuracy of a transmission loss, gain, or power measurement is affected by reflections from the test port, the device under test, and the detector. These errors are minimized by the very low reflections from the Wiltron SWR Autotesters and detectors.

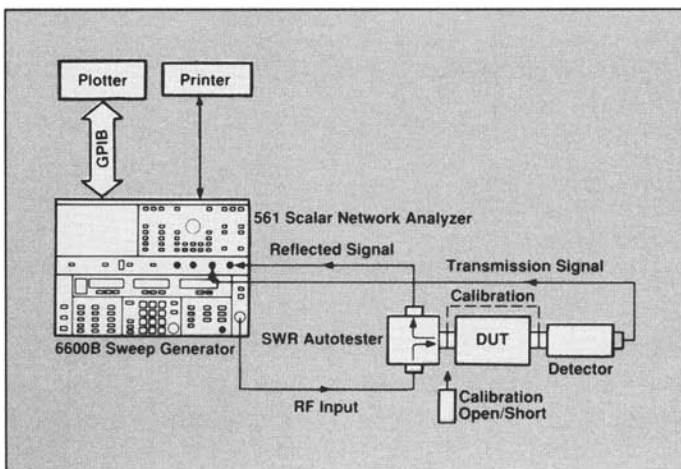

The 561 test setup includes direct connection to a printer or GPIB plotter. An external controller can be added, but is not required for automated measurements.

Zero-biased Schottky diodes are used in all detectors to minimize drift and circuit complexity. Except for the 560-7K50, diode modules are field-replaceable, eliminating the expense and inconvenience of returning the detectors to a service center for repair.

The accuracy of the 561 is high also because modulation of the input signal is not required. The need for modulation is avoided by using self-balancing amplifiers, which are stable at low signal levels. As a result, errors from modulation asymmetry and modulation-sensitive test devices are nonexistent. Without the insertion loss of a modulator, measurements can be made at higher input levels, increasing the measurement dynamic range.

Recommended Signal Sources

There are many advantages in selecting the Wiltron 6600B Sweep Generator as the 561 signal source. One advantage is the power sweep. In this mode, the output power is swept over a 15 dB range, enhancing gain compression measurements. In the alternate sweep mode, the 561 can display frequency response over different frequency ranges and/or power levels.

Another advantage of using a Wiltron signal source is that the 6600B uses fundamental oscillators from 2 to 26.5 GHz, avoiding the serious errors introduced by the subharmonics of frequency multipliers.

Stored Test Setups

Set-up time is reduced substantially by storing up to nine front-panel setups, four of which include their own calibration data. A unique preview feature allows stored setup parameters to be reviewed before recalling or storing a new setup in the memory location. The stored data are backed by a battery with an estimated 10-year life.

GPIB Compatibility

An IEEE-488 (GPIB) interface is standard, providing remote control of all front-panel functions except power on/off and CRT intensity. A high speed data transfer can be used to transfer measurement data to the host computer. This capability is especially useful in manufacturing environments where archiving of data is required.

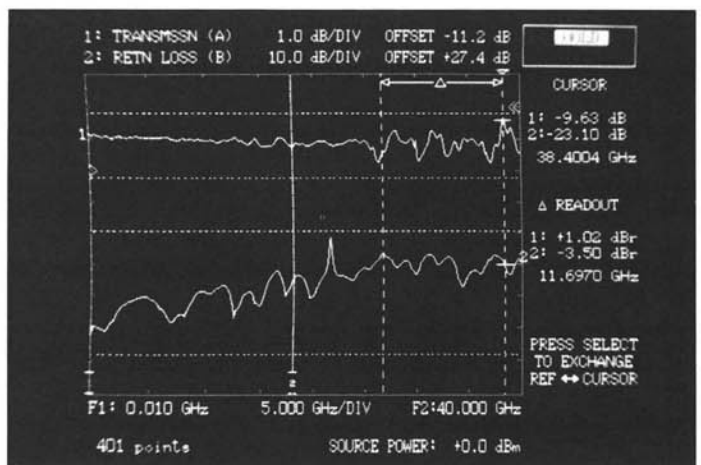

The 561 displays frequencies, differences in frequencies, amplitudes, differences in amplitudes, and pass/fail performance on the large, easy-to-read screen.

Scalar Network Analyzer (Cont.)

Model 561

Specifications

MEASUREMENTS

Measurement Modes: Measures and displays in dB swept transmission and return loss characteristics. Power is displayed in dBm. Complete measurement parameters for all modes are displayed.

Frequency Range: 10 MHz to 40 GHz in coax using Wiltron 560 Series Detectors and SWR Autotesters. Measurements can be made at higher frequencies with user-supplied waveguide detectors and Wiltron 560-10BX or 560-10BX-1 Adapter Cables.

Inputs: Four inputs, A, B, R1, and R2 accept detected outputs from Wiltron 560 Series Detectors and SWR Autotesters.

Dynamic Range: 71 dB (-55 dBm to +16 dBm) on all channels, usable to -60 dBm. Noise floor is typically less than -62 dBm.

Data Correction: System residuals, including the average of open and short reflections, are stored during normalization for automatic subtraction from test data.

Normalization: During the normalization sequence, 2001 points for each trace are stored with 0.002 dB resolution over any user-selected frequency range. Normalization data are automatically interpolated for ranges less than the original normalized range.

Save/Recall: Nine sets of front-panel settings can be stored for later recall. All stored data can be previewed on the CRT or printer output prior to selection. Four of the setups include their own calibration data.

DISPLAY

Channels: Two channels are used to select and simultaneously display any two inputs from A, B, R1, or R2. The same inputs can be displayed as ratios of A/R1, A/R2, B/R1, or B/R2.

Alternate Sweep: Displays alternate sweeps between the current front-panel setup and any of nine stored setups.

Graticule: Ten vertical divisions. Horizontal divisions are set automatically in frequency increments of a 1, 2, 5, sequence. Graticule On/Off control turns all graticule lines off. Tick marks remain on axis to indicate graticule position.

Display Resolution:
Horizontal: 101, 201, or 401 points over selected frequency range.
Vertical: 0.005 dB

Limit Lines: Two horizontal lines or complex limit lines with up to nine segments can be set for each trace. By switching off the standard graticule, a custom graticule can be constructed with the limit lines and frequency markers. Complex limit lines can be entered through the front panel or GPIB interface.

Scaling:
Resolution: 0.1 dB to 10 dB per division in 0.1 dB steps with independent control for each channel.
Offset Range: -99 dB to +99 dB in 0.1 dB steps.
Autoscale: Automatically selects offset and resolution to provide optimum display of test data.

Trace Update Time: Typically less than 100 ms, varying with frequency range and the averaging and smoothing settings.

Smoothing: Off, Minimum, and Maximum selections use analog techniques to reduce noise on low-level traces. Trace update time is automatically adjusted for any combination of averaging and smoothing.

Averaging: 2, 4, 8, 16, 32, 64, 128, or 256 successive traces can be averaged to smooth the trace display.

CRT Intensity: Continuously adjustable from off to bright.

MARKERS AND CURSOR

Markers: Displays up to eight numerically identified markers generated by the 6600B Sweep Generator. When a marker is selected as "Active," the cursor can be moved directly to the marker. The cursor can also be moved sequentially through markers until the desired marker is reached.

Main Cursor: Continuously variable with the tuning knob. The frequency and amplitude of test data at the cursor on both traces are digitally displayed.

Cursor Delta: Displays differences in dB and frequency between the reference cursor and the Main Cursor on both traces. A menu selection reverses the position of the reference cursor and the Main Cursor.

Cursor Min/Max: Automatically moves the cursor to the minimum or maximum value of test data on either trace.

Cursor "X" dB: Automatically moves cursor on either trace to an amplitude that is equal to the entered value of "X" dB or dBm.

Cursor "X" Bandwidth: Automatically displays cursors to the right and left of the cursor at the frequencies where the test data are equal to the entered value of "X" dB. The frequencies of the low and high cursors and the bandwidth between them are displayed.

Cursor Next Marker: Moves cursor to next highest frequency marker.

Cursor Active Marker: Moves cursor to the frequency of the active marker.

SIGNAL SOURCE

Recommended Signal Source: The Wiltron 6600B Sweep Generators are directly compatible with the 561. A dedicated GPIB system interface supplies frequency annotation on the 561 display.

Compatibility: The 561 is compatible with any signal source that meets the following requirements:

Horizontal Ramp: Provides a 0V to +10V nominal ramp signal, +12V maximum.

Blanking Signal: Provides +5V during retrace and bandswitching.

Dwell Signal: Accept TTL-low signal to dwell sweep ramp.

ACCURACY

Channel Accuracy (25°C):

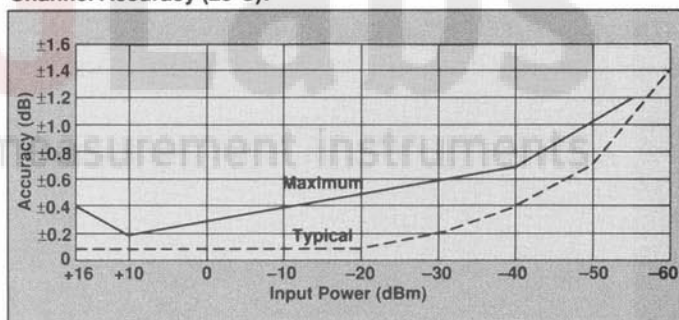

Transmission Loss or Gain Accuracy: Uncertainties from frequency response of components are automatically subtracted from test data during the normalization procedure. Overall accuracy is then:

$$\text{Transmission Loss or Gain} = \text{Channel Accuracy} + \text{Mismatch Uncertainty}^*$$

* Effects of sweep generator, test device, SWR Autotester and detector mismatch can be significant. This mismatch uncertainty is minimized by Wiltron's exceptionally low reflection characteristics of the detector, sweep generator and SWR Autotester.

Mismatch Uncertainty (Typical)**:

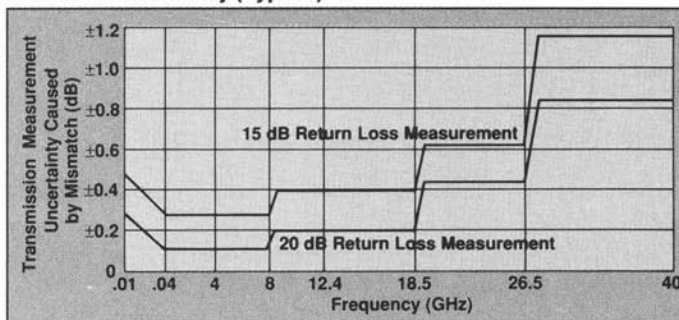

**Varies with the return loss of the detector, SWR Autotester, connecting cables, the source impedance of the sweep generator, and the value of the measured reflection.

Overall Coaxial Return Loss Measurement Accuracy:
Uncertainties resulting from SWR Autotester and sweep generator frequency response and from system open and short characteristics are subtracted automatically from test data. Overall accuracy is then:

$$\text{Return Loss Accuracy} = \text{Channel Accuracy} + \text{SWR Autotester Accuracy}$$

SWR Autotester Accuracy:

Model	Accuracy of Measured Reflection Coefficient (ρ) [*]			
	10 MHz–8 GHz	> 8–18 GHz	>18–26.5 GHz	> 26.5–40 GHz
560-97A50	0.016±0.06 ρ^2	0.016±0.1 ρ^2	N/A	N/A
560-97A50-1	0.010±0.06 ρ^2	0.010±0.1 ρ^2	N/A	N/A
560-97N50	0.018±0.08 ρ^2	0.018±0.12 ρ^2	N/A	N/A
560-97N50-1	0.013±0.08 ρ^2	0.013±0.12 ρ^2	N/A	N/A
560-97NF50	0.018±0.08 ρ^2	0.018±0.12 ρ^2	N/A	N/A
560-97NF50-1	0.013±0.08 ρ^2	0.013±0.12 ρ^2	N/A	N/A
560-98K50	0.018±0.15 ρ^2	0.018±0.15 ρ^2	0.025±0.15 ρ^2	0.032±0.18 ρ^2
560-98KF50	0.018±0.15 ρ^2	0.018±0.15 ρ^2	0.025±0.15 ρ^2	0.032±0.18 ρ^2
560-98S50	0.025±0.1 ρ^2	0.025±0.1 ρ^2	0.025±0.1 ρ^2	N/A
560-98S50-1	0.013±0.1 ρ^2	0.013±0.1 ρ^2	0.018±0.12 ρ^2	N/A
560-98SF50	0.025±0.1 ρ^2	0.025±0.1 ρ^2	0.025±0.1 ρ^2	N/A
560-98SF50-1	0.013±0.1 ρ^2	0.013±0.1 ρ^2	0.018±0.12 ρ^2	N/A

* Accuracy includes the effects of directivity (first term) and test port reflection (second term) over the frequency range.

Power Measurement Accuracy:

$$\text{Absolute Power Accuracy} = \text{Channel Accuracy} + \text{Detector Frequency Response}$$

Detector Frequency Response:

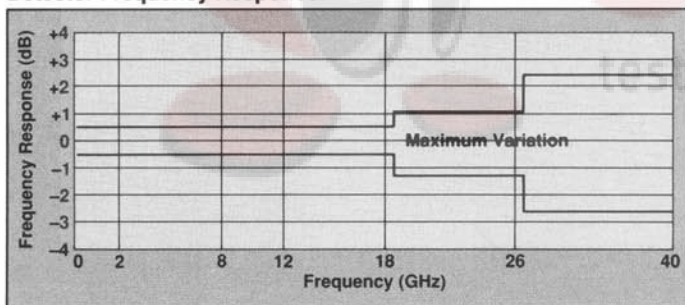

Overall Waveguide Return Loss Measurement Accuracy:

$$\text{Return Loss Accuracy} = \text{Channel Accuracy} + \text{User-Selected Coupler Accuracy}$$

In addition, mismatch uncertainties introduced by the detectors used in a waveguide reflectometer setup can be significant.

GPIB

Interface: IEEE-488 interface is standard on all instruments. All front-panel controls are GPIB controllable except power on/off and CRT intensity. Pass-through commands allow control of the microwave signal source through the 561 GPIB port.

Data Transfer: The 561 does not require an external controller; nevertheless, it is capable of providing high speed data transfer of test data and normalization data to an external GPIB controller.

PRINTER/PLOTTER

Plotter: Dedicated GPIB interface is compatible with HP 7440A, HP 7447A, and HP 7475A Plotters. Display traces, markers, cursor, and graticule information are copied. When overlay traces are desired, data traces only can be plotted.

Printer: Parallel printer interface is compatible with most dot-matrix printers, including Epson FX and the optional 2225C Ink Jet Printer. Hard copy output in graphical or tabular format can be selected.

Selections include graphics with measurement parameters, test data tabulated for 26, 51, 101, 201, or 401 points, marker parameters only, or stored setup parameters.

Internal Print Buffer: After approximately 10 seconds of print formatting, a new test can be conducted while previously taken test data are being printed out from an internal printer buffer.

INPUT/OUTPUT CONNECTIONS

Horizontal Sweep Ramp Input: 0 to +10V nominal, +12V maximum.
Sequential Sync Input: +3.5V to +10V blanks trace during retrace or bandswitching. -3.5V to -10V defines a marker which when in the range of -8V to -10V is an active marker. Rear panel BNC connector, 10K ohm impedance.

Sweep Dwell Input: TTL-low signal stops sweep. Sweep continues when signal is removed. Rear panel BNC connector.

Bandswitching Blanking Input: Accepts ±5V signal coincident with bandswitching points. Rear panel BNC connector.

Retrace Blanking Input: +5V blanks traces during retrace. Rear panel BNC connector.

Video Marker Input: ±1V to ±10V peak input. Rear Panel BNC connector.

System GPIB: Connects 561 to GPIB. Rear panel GPIB connector.

Dedicated GPIB: Connects 561 to signal source and plotter. Rear panel GPIB connector.

Parallel Printer (Centronics): Connects 561 to printer. Rear panel.

AUX I/O: Connects 561 to Wiltron 6600B Sweep Generator. Rear panel.

External Display: Composite video signal from rear panel, BNC connector.

GENERAL

Temperature Range:

Operating: 0°C to +50°C

Storage: -40°C to +70°C

Power: 100V/110V/220V/240V ±10%, 50-60 Hz, 350 watts maximum

Dimensions: 311 H x 432 W x 476 D mm + 10 mm for feet.

(12-1/4 H x 17 W x 18-3/4 D in. +3/8 in. for feet)

Weight: 16 kg (35 lb)

MEASUREMENT COMPONENTS

SWR Autotester: The 560

Series SWR Autotesters

integrate in one small package

a broadband, high directivity

bridge, a detector, a low

reflection test port, a reference

termination, and a connecting

cable. The output of the SWR

Autotester is a detected signal,

varying in proportion to reflections from the test device connected to

the test port. Optional extender cables can be used without

degradation in performance.



Model	Frequency Range (GHz)	Directivity (dB)	Frequency Sensitivity (dB)	Test Port Connector	Input Connector
560-97A50	0.01-18	36	± 1.2	GPC-7	N Female
560-97A50-1		40			
560-97N50	0.01-18	35	± 1.5	N Male	N Female
560-97N50-1		38			
560-97NF50	0.01-18	35	± 1.5	N Female	N Female
560-97NF50-1		38			
560-98K50	0.01-40	30	± 3	K Male	Ruggedized K Female
560-98KF50				K Female	
560-98S50	0.01-26.5	32	± 2	WSMA Male	Ruggedized WSMA Female
560-98S50-1		35			
560-98SF50	0.01-26.5	32	± 2	WSMA Female	Ruggedized WSMA Female
560-98SF50-1		35			

Scalar Network Analyzer (Cont.)

Model 561

MEASUREMENT COMPONENTS (Cont.)

SWR Autotester Accuracy: Please see page 35.
Maximum Input Power: 0.5 W
Cable Length: 122 cm (4 ft)
Insertion Loss: 6.5 dB nominal from input port to test port.

Dimensions and Weight:

Model	Dimensions*	Weight
560-97A50, -1	7.6 x 5 x 2.8 cm	340 g
560-97N50, -97NF50, -1	(3 x 2 x 1-1/8 in.)	(12 oz)
560-98K50, -98KF50	1.9 x 3.8 x 2.9 cm	198 g
560-98S50, -98SF50, -1	(3/4 x 1-1/2 x 2-1/8 in.)	(7 oz)

* Plus connectors and cable

Detectors: The 560 Series Detectors are used for coaxial transmission loss or gain and power measurements and with coaxial adapters for waveguide reflectometer measurements. Zero-biased, field-replaceable Schottky diodes provide -60 dBm sensitivity. Optional extender cables can be used without degradation in performance.



Model	Frequency Range	Input Connector
560-7A50	10 MHz to 18 GHz	GPC-7
560-7K50	10 MHz to 40 GHz	K Male
560-7N50	10 MHz to 18.5 GHz	N Male
560-7S50	10 MHz to 18.5 GHz	WSMA Male
560-7S50-2	10 MHz to 26.5 GHz	WSMA Male
560-7S50-3	10 MHz to 34 GHz	WSMA Male

Detector Return Loss:

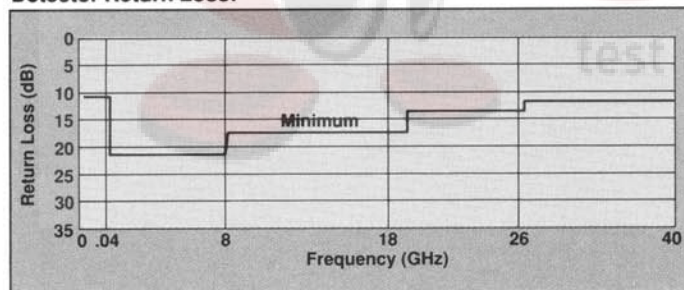

Maximum Input Power: 100 mW
Cable Length: 122 cm (4 ft)
Dimensions: 7.6 x 2.9 x 2.2 cm (3 x 1-1/8 x 7/8 in.)
Weight: 170 g (6 Oz)

Replaceable Diode Modules:

Detector Model	Diode Module Model	Price
560-7A50	560-A-7219-A	\$150
560-7K50	Factory Repair Only	\$275
560-7N50	560-A-7219-A	\$150
560-7S50	560-A-7219-A	\$150
560-7S50-2	560-A-7219-B	\$150
560-7S50-3	560-A-7219-C	\$150

ACCESSORIES

Extender Cables: Extender Cables can be installed between the SWR Autotester or detectors and the 561, permitting measurements from up to 200-foot distance.

Model	Cable Length	Price
800-109	7.6 m (25 ft)	\$50
800-110	15.2 m (50 ft)	\$75
800-111	30.5 m (100 ft)	\$100
800-112	61 m (200 ft)	\$180



GPIB Cables: GPIB cables interconnect instruments on GPIB.

Model	Cable Length	Price
2100-1	1 m (3.3 ft)	\$60
2100-2	2 m (6.6 ft)	\$75
2100-4	4 m (13.2 ft)	\$95
2100-5	0.5 m (1.65 ft)	\$55



Adapter Cables: Adapter cables allow the 561 to be used with waveguide or other detectors having a BNC or SMA female output connector. Cable length is 122 cm (4 ft).

Model	Connectors	Price
560-10BX	BNC Female	\$100
560-10BX-1	SMA Female	\$150



Open/Shorts: An Open/Short is used to establish a 0 dB return loss reference during the normalization procedure.

Model	Connectors	Price
21A-1*	GPC-7 Short Only	Included with instrument at no charge
22A50	GPC-7	
22K50	K Male	
22KF50	K Female	
22N50	N Male	
22NF50	N Female	
22S50	WSMA Male	
22SF50	WSMA Female	



* Supplied with collet for mating with beadless end of air line.

- 760-56 Transit Case for RF components \$305
- 760-75 Transit Case for the 561 \$390
- 2000-216 External Monitor, 260 mm (10.25 in.) diagonal . . . \$300
- 2225C Ink Jet Printer, including 2225-1 Interface Cable, 1 ink cartridge, and 50 sheets of Ink Jet paper. \$795

Ordering Information

561 Scalar Network Analyzer \$7,900

SWR Autotesters:

- 560-97A50, 10 MHz to 18 GHz, 36 dB directivity \$1,900
- 560-97A50-1, 10 MHz to 18 GHz, 40 dB directivity \$2,200
- 560-97N50, 10 MHz to 18 GHz, 35 dB directivity \$2,000
- 560-97N50-1, 10 MHz to 18 GHz, 38 dB directivity \$2,300
- 560-97NF50, 10 MHz to 18 GHz, 35 dB directivity \$2,050
- 560-97NF50-1, 10 MHz to 18 GHz, 38 dB directivity \$2,350
- 560-98K50, 10 MHz to 40 GHz, 30 dB directivity \$3,150
- 560-98KF50, 10 MHz to 40 GHz, 30 dB directivity \$3,200
- 560-98S50, 10 MHz to 26.5 GHz, 32 dB directivity \$2,400
- 560-98S50-1, 10 MHz to 26.5 GHz, 35 dB directivity \$2,900
- 560-98SF50, 10 MHz to 26.5 GHz, 32 dB directivity \$2,500
- 560-98SF50-1, 10 MHz to 26.5 GHz, 35 dB directivity \$3,000

Detectors:

- 560-7A50, 10 MHz to 18 GHz, GPC-7 \$550
- 560-7K50, 10 MHz to 40 GHz, K Male \$675
- 560-7N50, 10 MHz to 18.5 GHz, N Male \$525
- 560-7S50, 10 MHz to 18.5 GHz, WSMA Male \$525
- 560-7S50-2, 10 MHz to 26.5 GHz, WSMA Male \$600
- 560-7S50-3, 10 MHz to 34 GHz, WSMA Male \$675

Rack Mounting, Option 1: Unit supplied with mounting ears and chassis track slide (90° tilt) installed \$350

Connecting Cables: A 2100-1 GPIB Cable, 1 m (3.3 ft) long, and an 806-7 Interconnect Cable for the 6600B Sweep Generator are included with each 561.

Replacement Interconnect Cables 806-7 \$250